

30' Trail Model Wick Weeder Parts List

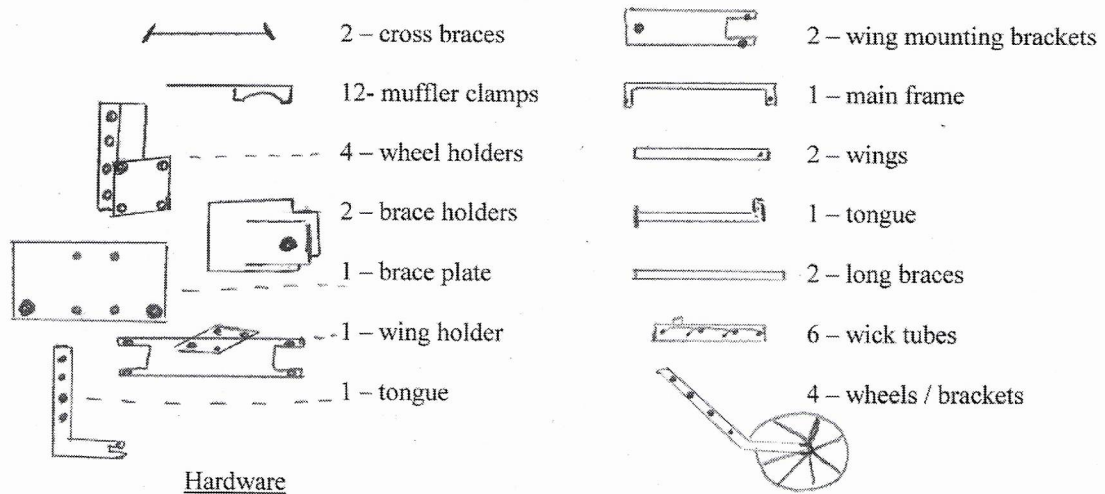

Hardware

12 - round 3" u-bolts
 4 - 3/8" x 3 1/2" bolts
 8 - 1/2" x 3 1/2" bolts
 10 - 1/2" lock nuts
 2 - 2 1/2" x 1/2" bolts

10 - pins
 10 - hair pins
 100 - nuts
 33 - square u-bolts
 1 - 3/4" x 1 1/2" locking bolt

Slow Moving Vehicle Sign & Holder

1 - smv sign
 2 - 1/4" x 1" bolts

1 - 2" flat steel for smv sign
 2 - 1/4" nuts

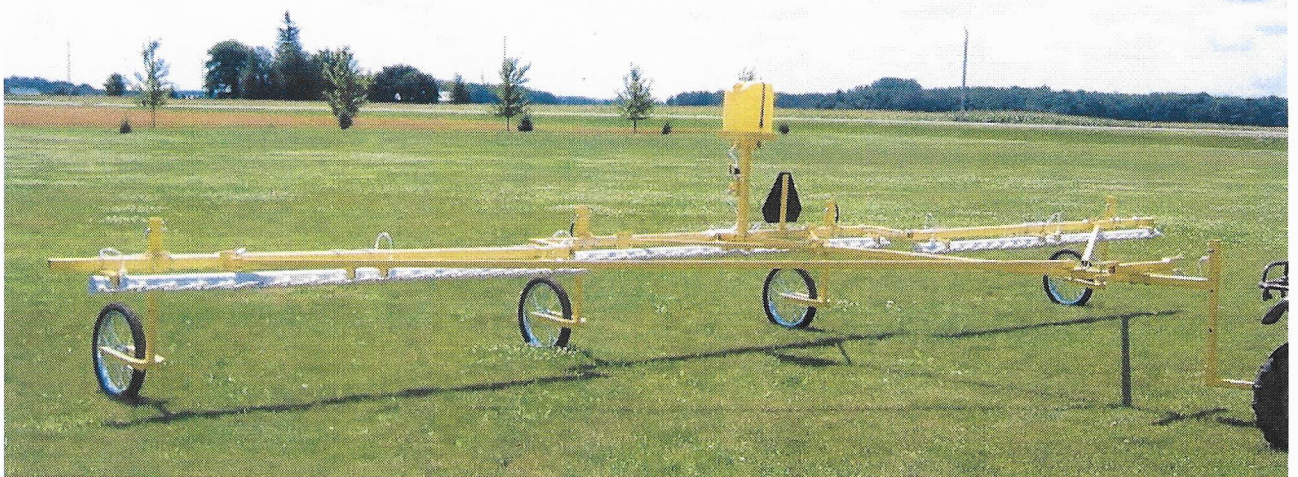

30' Trail Model Wick Weeder Assembly

10' Main Frame

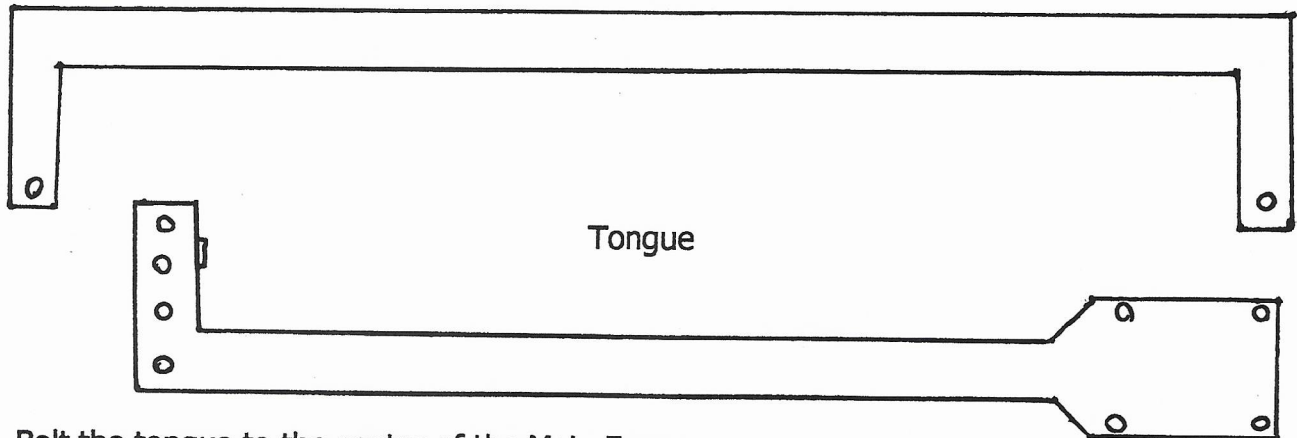

Bolt the tongue to the center of the Main Frame
Make sure that you are in the center of the frame or it will not pull straight when going down the field.

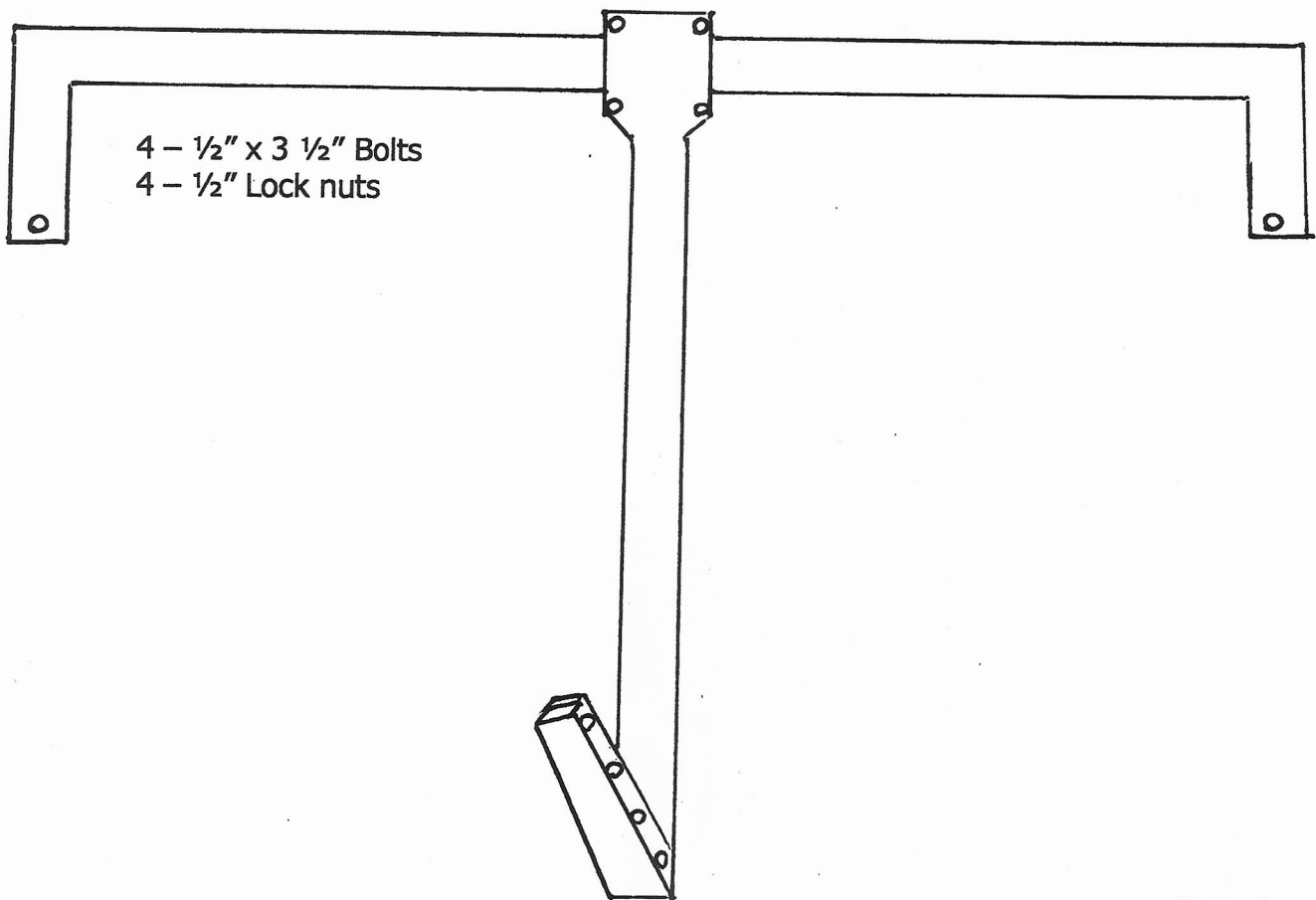

Mounting Wheels

Wheel Holder

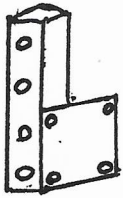

Hitch

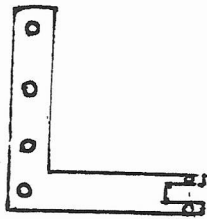

Wheel

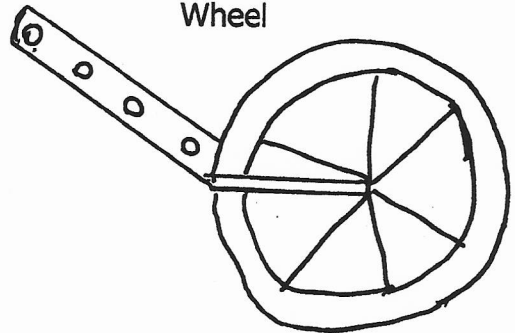

The wheel holders go close to the end of the main frame on the back side. Place according to your crop row width. They are mounted with 2 - 2" square U-bolts and 4 - 3/8" flange nuts. The flat plate goes to the bottom. Slide wheels into wheel holders and secure with pin & hairpin. Insert hitch and secure with pin & hairpin. (see picture) You will also notice a nut welded onto the tongue, there is a locking bolt that you should screw into here and tighten up.

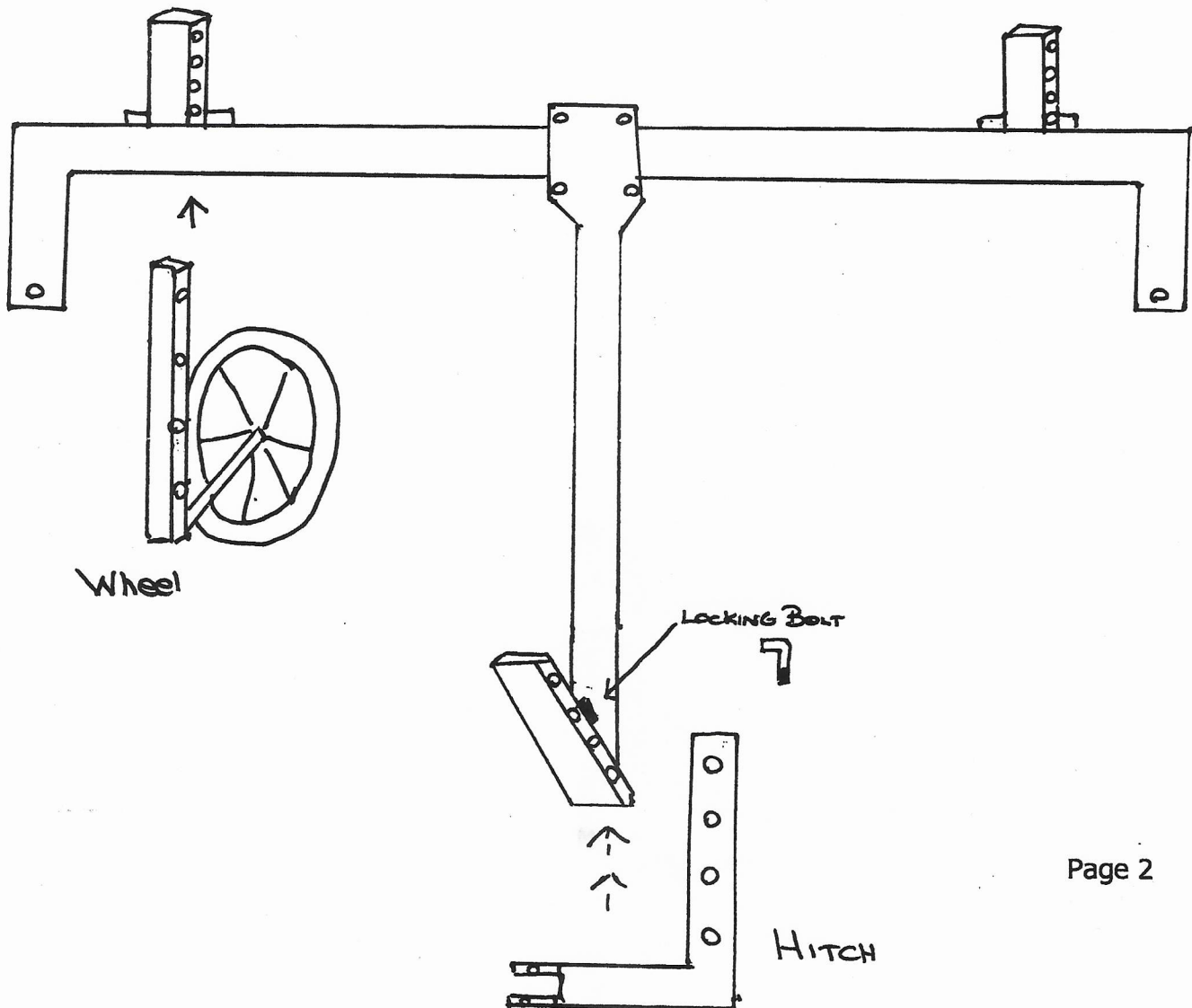

Wheel Holder / wheel



The wheel goes on the back side of the frame.

Cross braces

Secure with 4 - $\frac{3}{8}$ " x $3\frac{1}{2}$ " bolts and $\frac{3}{8}$ " flange nuts at the tongue.
On the main frame use 2 - 2" square u-bolts and 4 - $\frac{3}{8}$ " flange nuts.

Before tightening them, measure from the front to the outside ends. This is done to make sure that when the unit is finished it will pull straight. If they do not measure close to the same you can adjust your cross braces to correct this and then tighten them up.

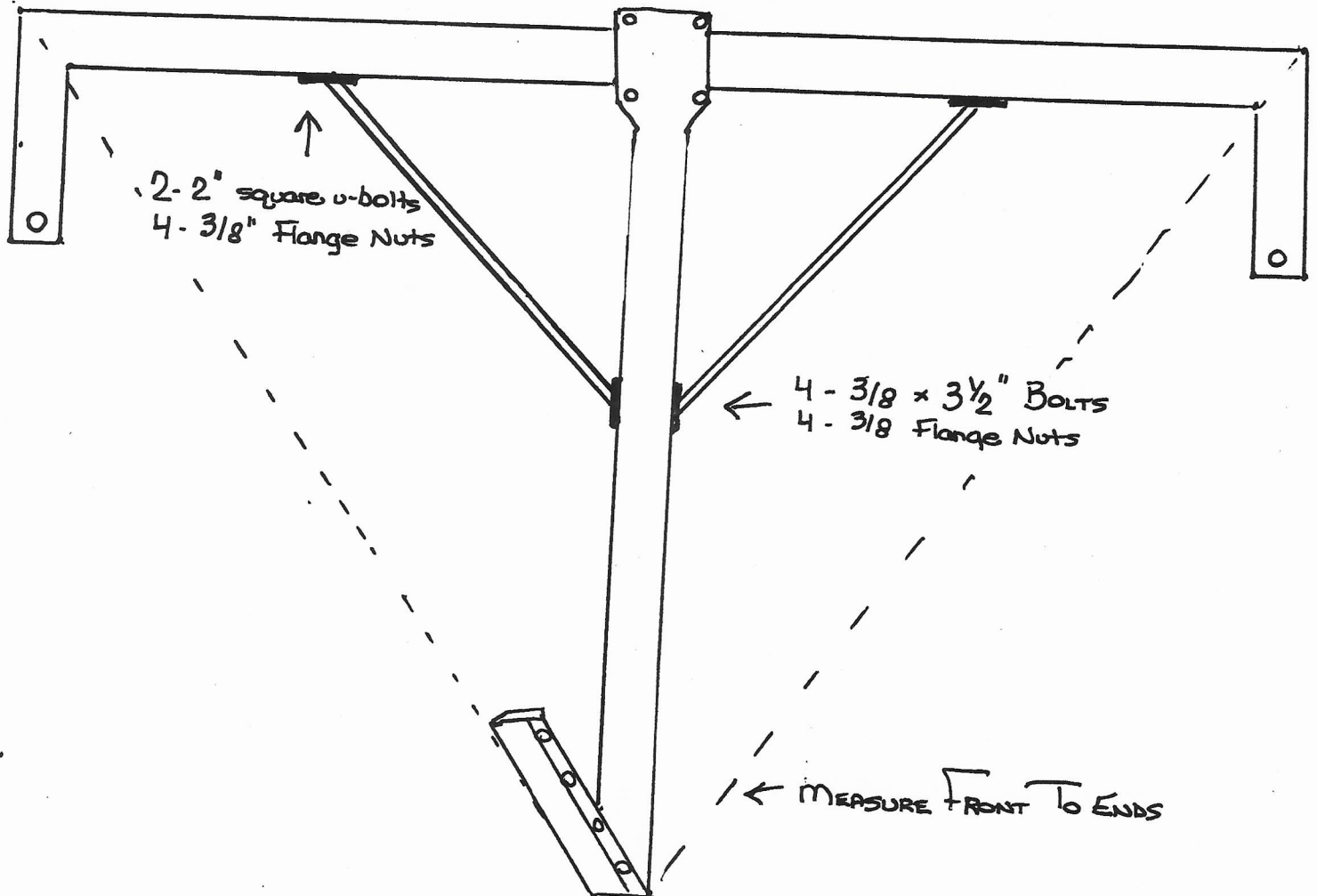

Wings

Bolt on the hinges with 2 - 1/2" x 3 1/2" bolts and 2 - 1/2" lock nuts

The end on the wing with just the hole drilled into it is the end that attaches to the hinge. Bolt on with 2 - 1/2" x 3 1/2" bolts and 2 - 1/2" lock nuts.

Wheel Brackets / Wheels

Mount the rest of the wheel brackets on the wings. Place them according to your crop row width. Secure with 2 - 2" square u-bolts and 4 - 3/8" flange nuts. Insert wheels securing with pin and hair pin.

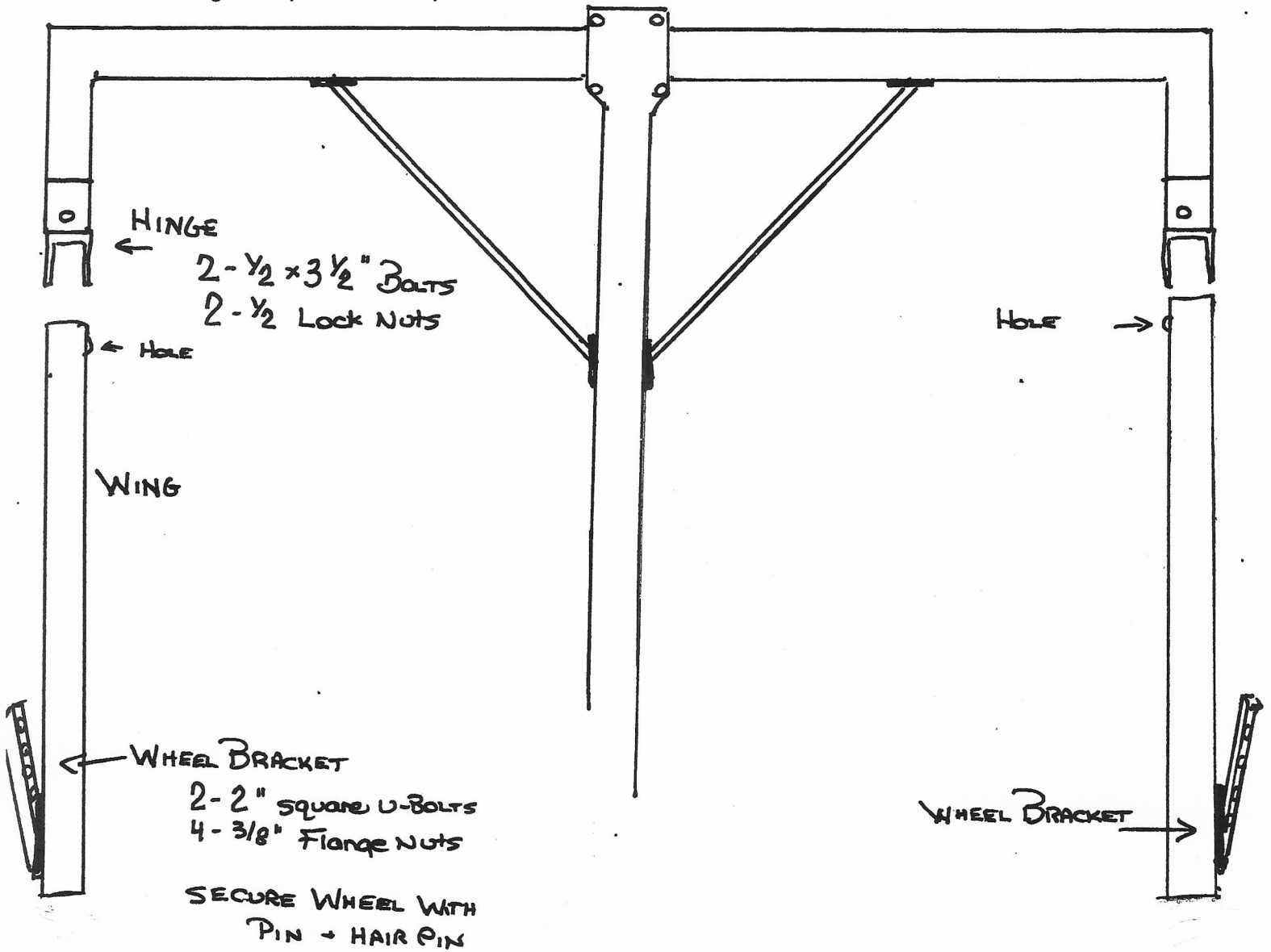

Mounting the Wick Tubes

Place the muffler clamp approx. 4" in from the end, with 1 - 2" square u-bolt and 2 - 3/8" flange nuts. Bolt clamp to the underside of the tubing. (see Picture)

Mount the wick tubes with 3" round u-bolts and 3/8" flange nuts.

Mount wick tubes as seen in the picture. Wicks go straight ahead, fill cap at the top.

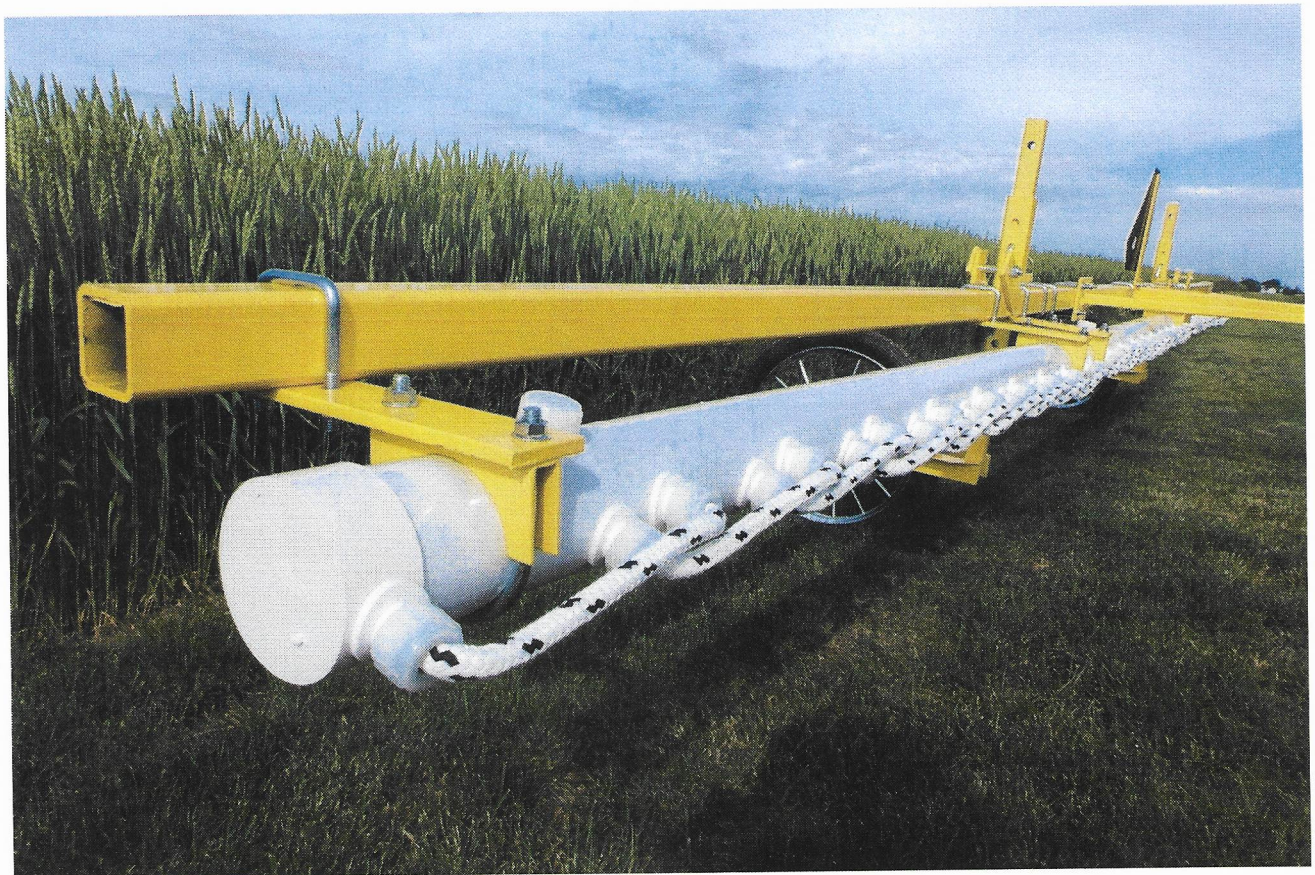

Wing Holder – The wing holder lays on the top of the tubing on the tongue and is secured with 2 – 2" square u-bolts and 4 – 3/8" flange nuts. (see picture)

Roll the wings ahead to a transport position. This will help you decide where exactly the wing holder should be. The wings should slide into the wing holder and get secured with 2 – pins and 2- hairpins.

Flat Plate – Secure it to the tongue with 2 – 2" square u-bolts and 4 – 3/8" flange nuts. Lay the braces on top of the plate and fasten with 2 – 1/2" x 2 1/2" bolts and 1/2" lock nuts.

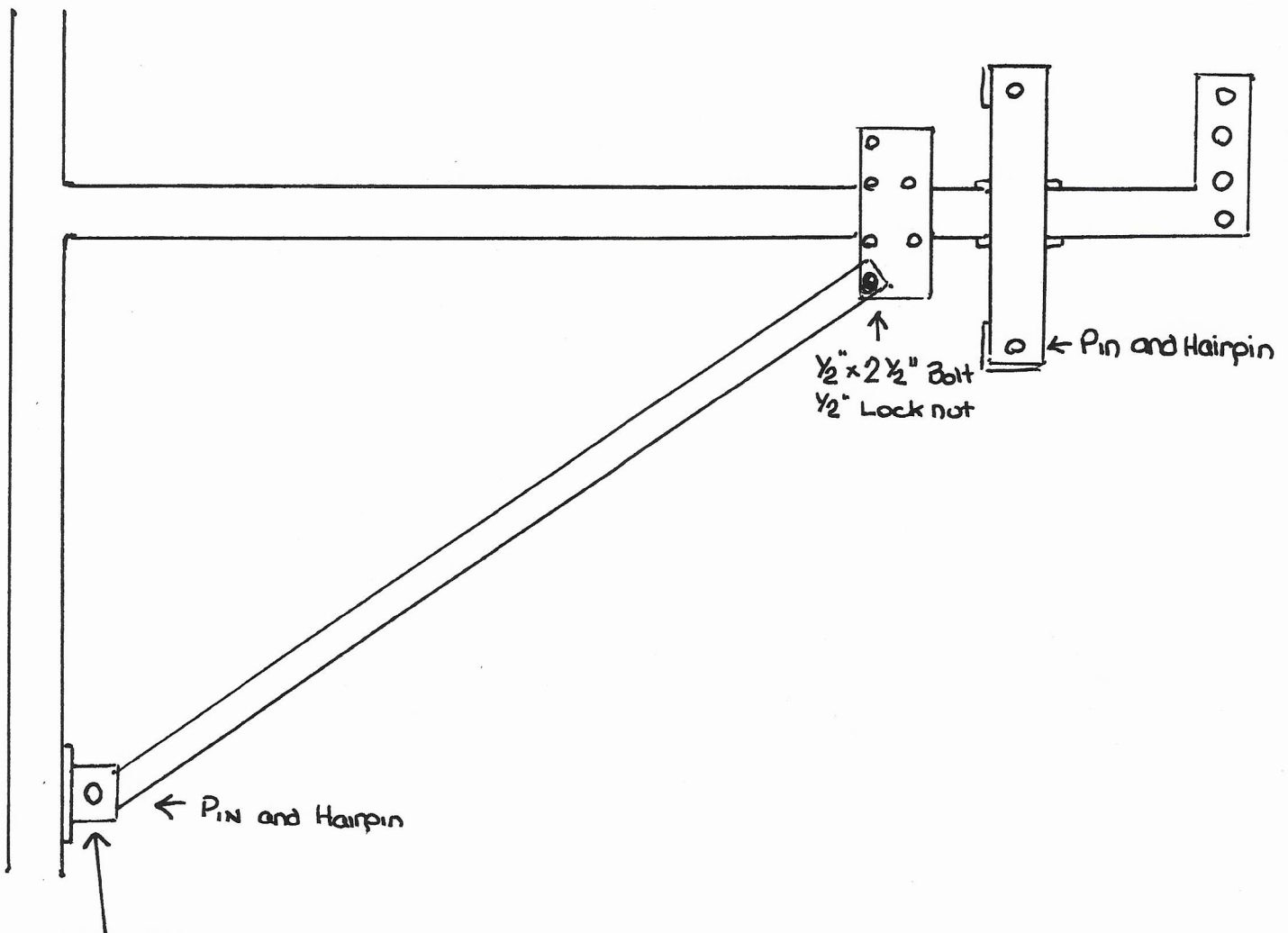

Brace Holder

The brace holder goes on the front side of the tubing bolted on with 2 – 2" square u-bolts and 4- 3/8" flange nuts. Slide the brace holder to wherever the braces should be.

Long Braces

Place the long brace on top of the flat plate on the tongue and secure with 2 – 1/2" x 2 1/2" bolts and 1/2" lock nuts.

The other end will be inserted into the brace holder bracket and locked on with a pin and hair pin.

For Transport pull the pins at the brace holders and put braces straight back down the center of the weeder. Then roll the wings ahead and put them into the wing holder. Your transport width will be 10'.

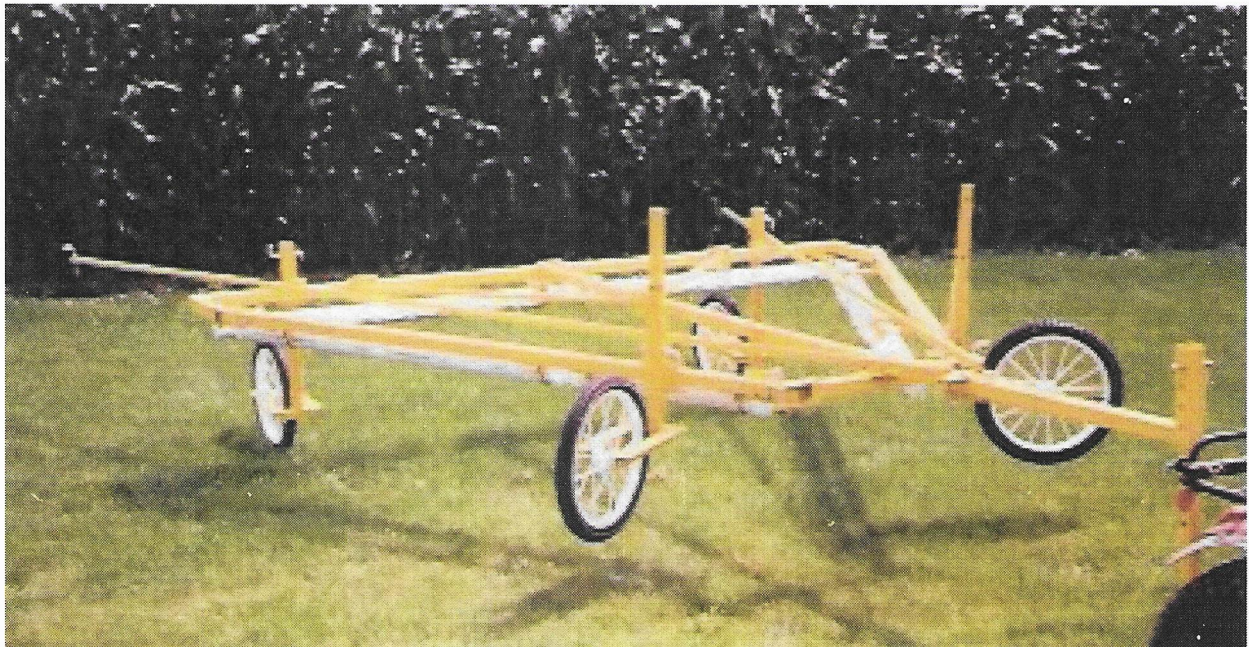

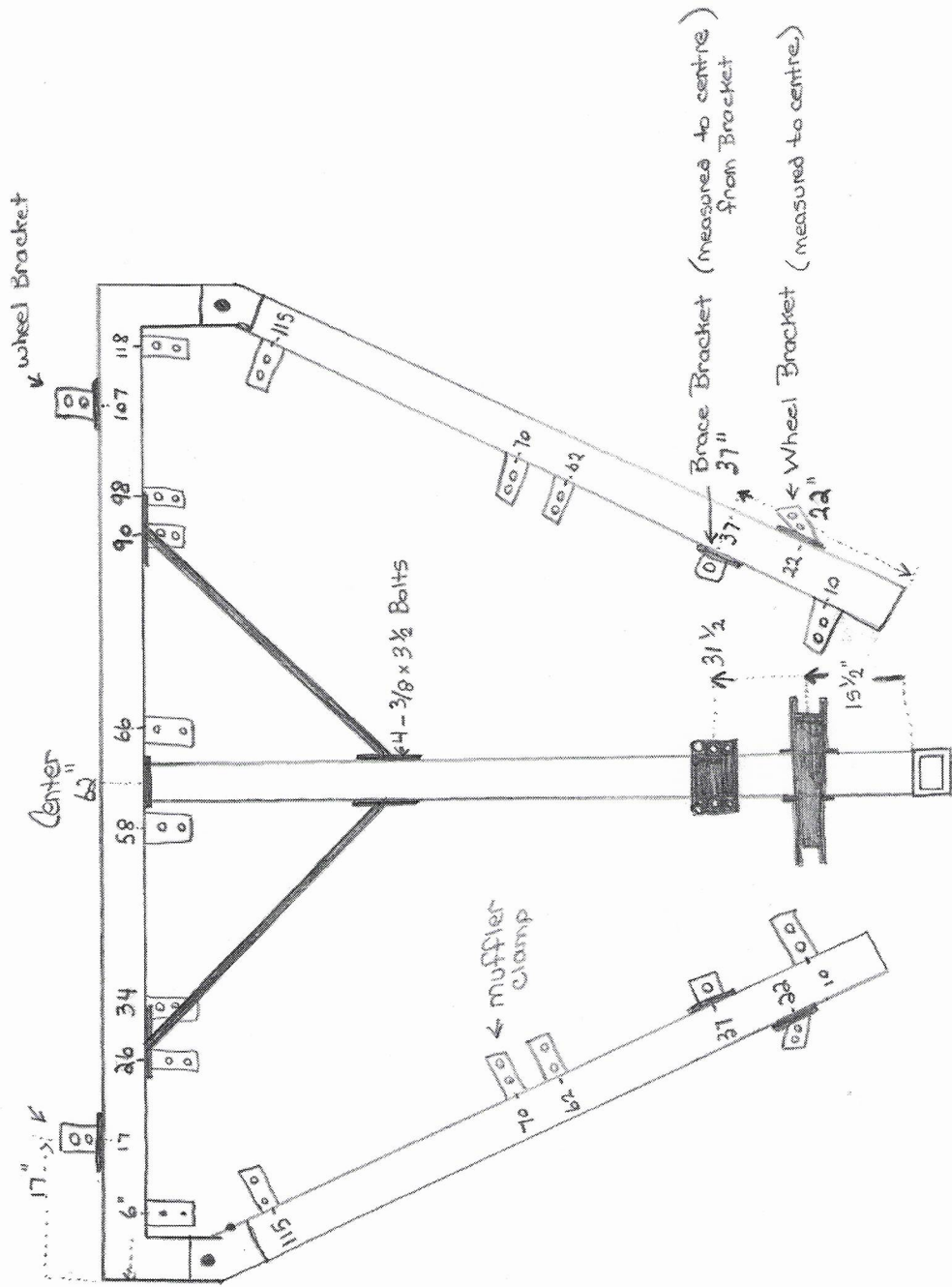

• Always measured to centre

30' TRAIL MODEL