

## 20' Trail Model Wick Weeder Parts List

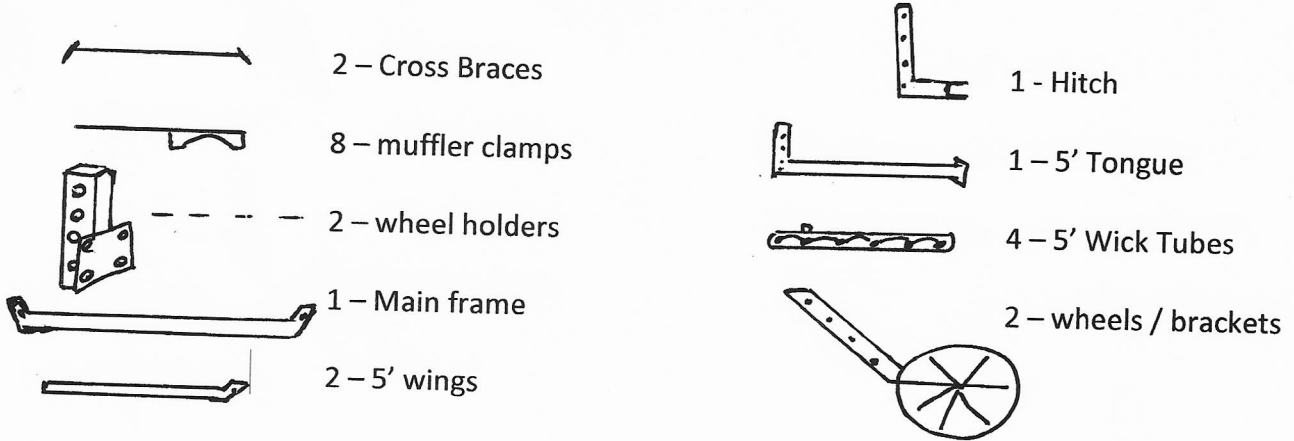

2 – Cross Braces

8 – muffler clamps

2 – wheel holders

1 – Main frame

2 – 5' wings

1 - Hitch

1 – 5' Tongue

4 – 5' Wick Tubes

2 – wheels / brackets

### Hardware

8 – 3" round u-bolts

4 – 3/8" x 3 1/2" bolts

2 – 1/2 x 3 1/2" bolts

2 – 1/2" lock nuts

1 – 3/4" locking bolt

4 – pins

4 – hair pins

58 – 3/8" flange nuts

19 – 2" square u-bolts

### SMV Sign & Holder

1 – smv sign

2 – 1/4 x 1 bolts

1 – 2" flat steel for smv sign

2 – 1/4" nuts



Assembly Instructions:

- 10' long main frame
- Take the 5' tongue and but the flat plate up against the center of the 10' long main frame.
- Bolt them together with 2 – 2" u-bolts and 3/8" flange nuts. (Make sure it is in the center or it will not pull straight.)

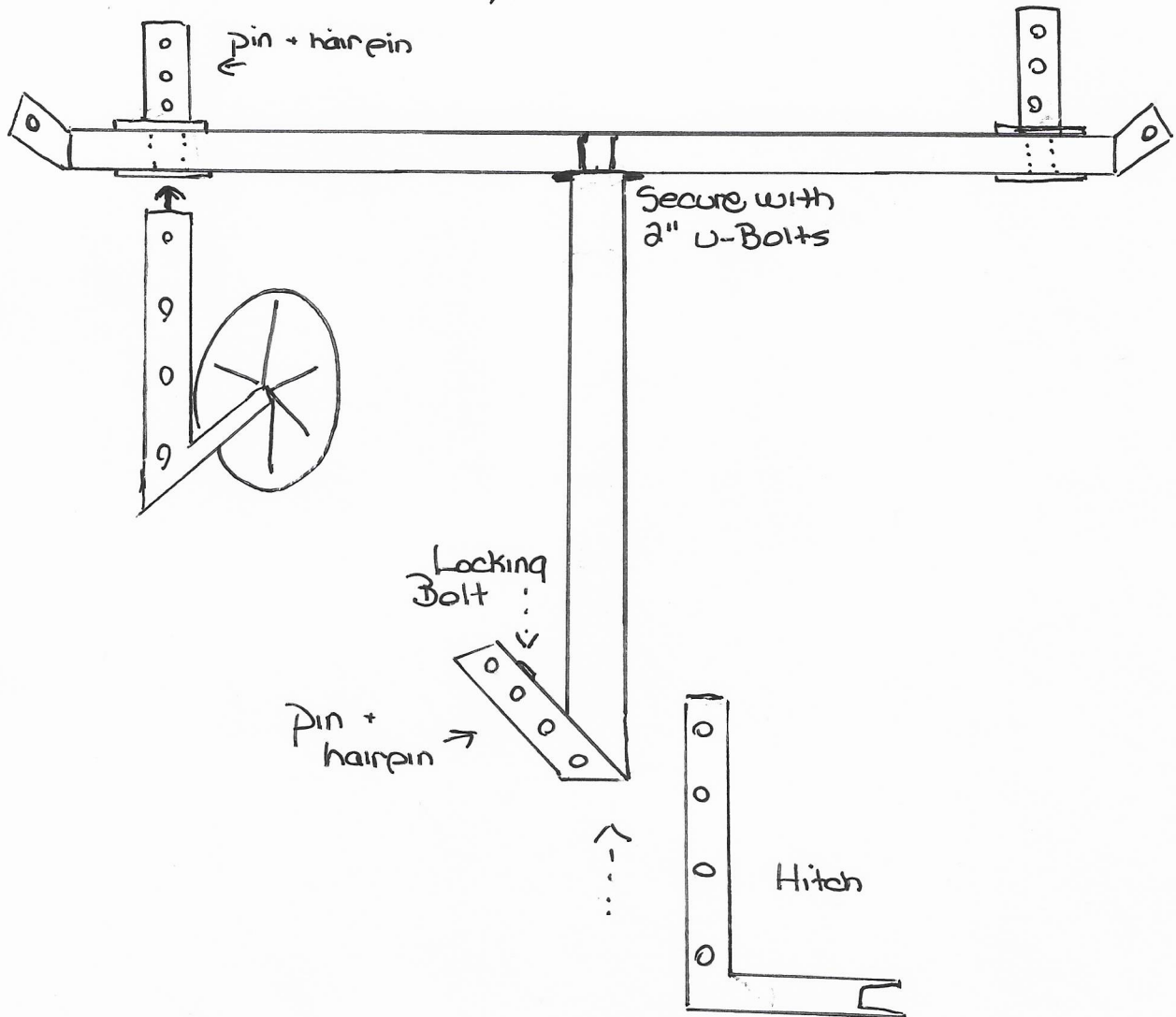

- Next you get the 2 wheel holders and place them on the back side of the 10' main frame, close to the end. (place them according to your row width)
- They are mounted with 2 – 2" u-bolts and 3/8" flange nuts. The flat plate goes to the bottom with the rest sticking up.
- Slide your wheels into the wheel holders and secure with a pin and a hair pin.
- Slide your hitch into the tongue and secure with a pin and a hair pin
- There is a locking bolt that should also be screwed into the tongue to tighten the hitch.

- Next you can put on the cross braces. They are joined together on the 5' tongue with 4 – 3/8" x 3 1/2" bolts and flange nuts.
- Secure them to the 10' main frame with 2" u-bolts and flange nuts.
- Before tightening them measure from the front to the outside ends. This is done to make sure that when the unit is finished it will pull straight.
- If they do not measure close to the same you can correct this by adjusting your cross braces, and then tighten them up.

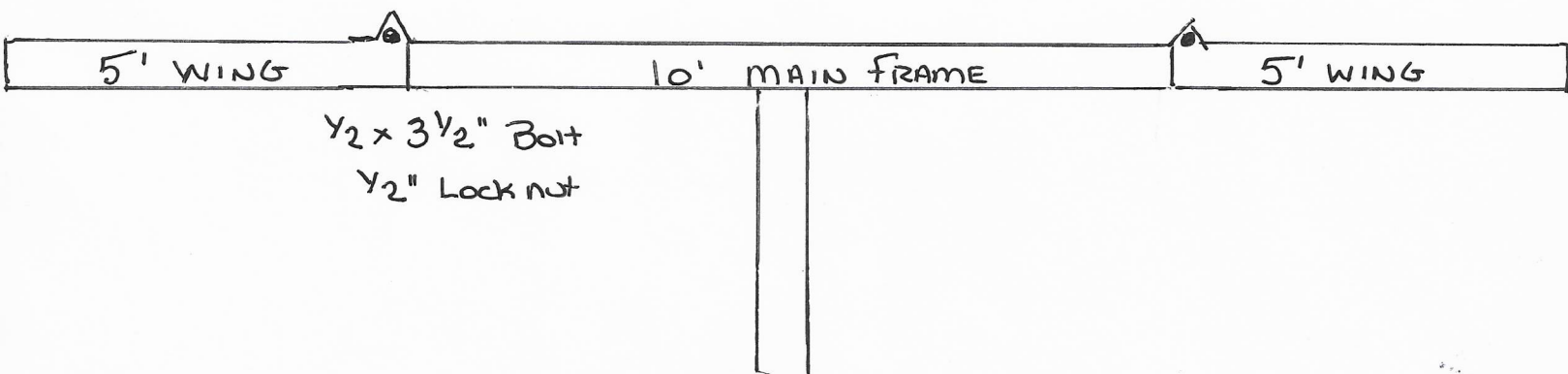
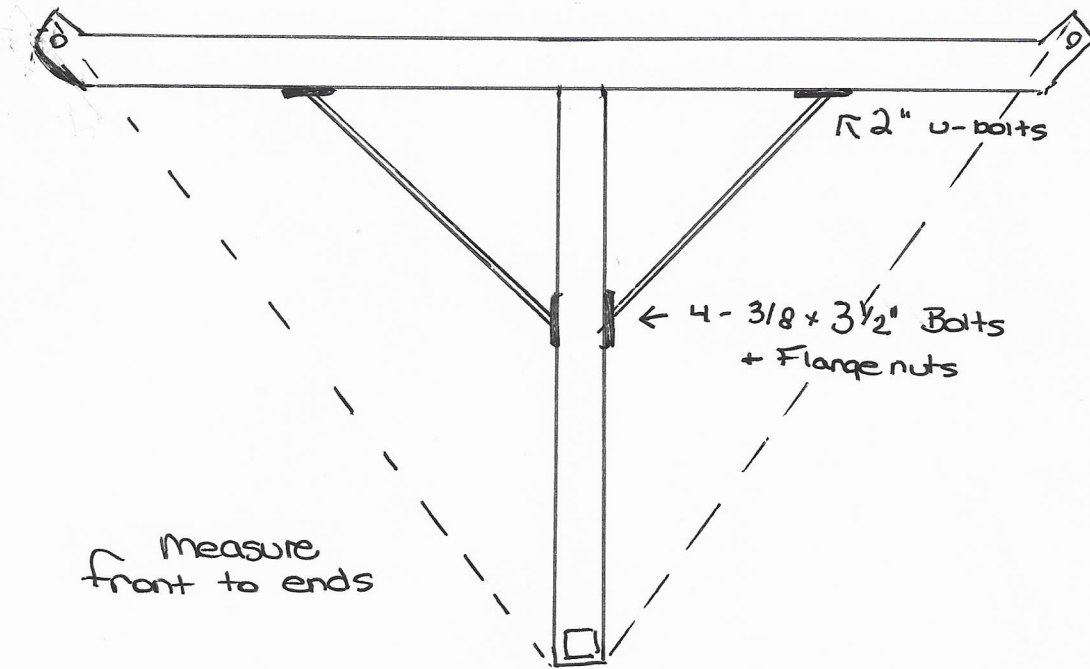

- Now you can bolt on the 5' wings with a 1/2" x 3 1/2" bolt and 1/2" lock nut.

- Your muffler clamps are mounted to the underside of the tubing with a 2" u-bolt and flange nuts. Place them 4" in from the ends. The wick tubes are all 5' long.
- Now you are ready to mount the wick tubes with the 3" round u-bolts. Slip the u-bolt over the tube beside the end cap and then slide the u-bolt into the muffler clamp. When fastening be sure not to tighten too tight, it should be snug, but the pipe should not indent from over tightening. Make sure that the fill cap is at the top of the wick tube and that the ropes face straight ahead.
- DO NOT mount the wick tubes with the ropes facing straight down toward the ground. This puts too much pressure on the ropes when the wick tubes are full, and they will leak.
- To fold for transport just flip the 5' wing over onto the 10' main frame.

