

# 15' Flex Trail Parts & Direction Sheet

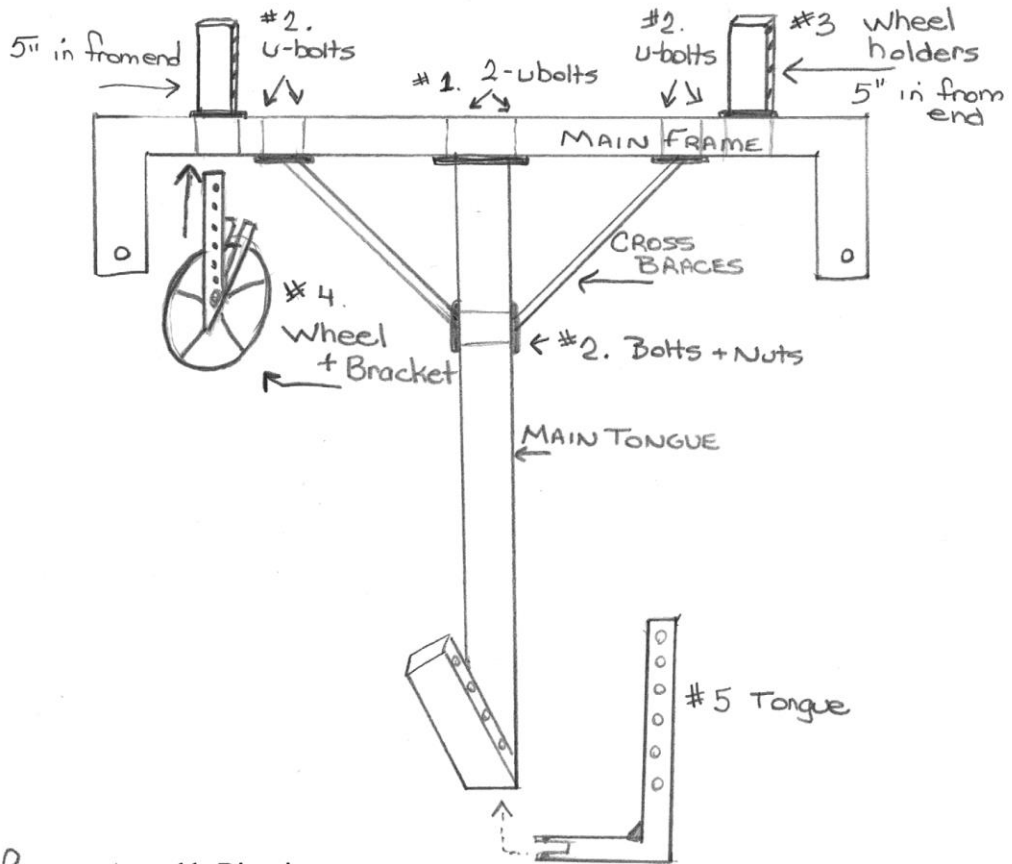

# 15' Flex Trail - Parts Sheet

3	Heavy 5' Wick Tubes
4	Wheels on Brackets
1	7 ½ ' Main Tongue
1	5' Main Frame
1	Tongue
2	Braces
2	Short angle braces
2	5' wings
1	Wing Holder
1	Brace Plate
4	Wheel Brackets
6	Muffler Clamps
2	Hinges
2	Brace Holders
1	SMV sign
1	2" flat steel for SMV sign
6	Round 3" u-bolts
4	3/8 x 3 ½ bolts
4	½ x 3 ½ bolts
6	½ " Lock nuts
2	½ x 1 ½ bolts
10	Pins
10	Hair Pins
1	¾" Locking Bolt
29	Square 2" u-bolts
74	3/8 " Flange Nuts
2	¼ x 1 bolts
2	¼" nuts



Assembly Directions:

1. Bolt the main tongue to the main frame with u-bolts.
2. Put on the cross braces with 4- 3/8 x 3 1/2 bolts onto the main tongue and u-bolts onto the main frame. (make sure you measure from the tongue to the ends of the main frame, to make sure the frame will pull straight when you are towing the unit)
3. Bolt on 2 wheel holders using u-bolts, close to the ends of the main frame. (they should be placed for your row width)
4. Slide in the wheels (that are mounted to their bracket) and secure with a pin and hair pin.
5. Slide in the tongue into the front of the main tongue and secure with a pin & hair pin.

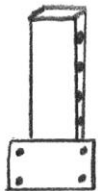

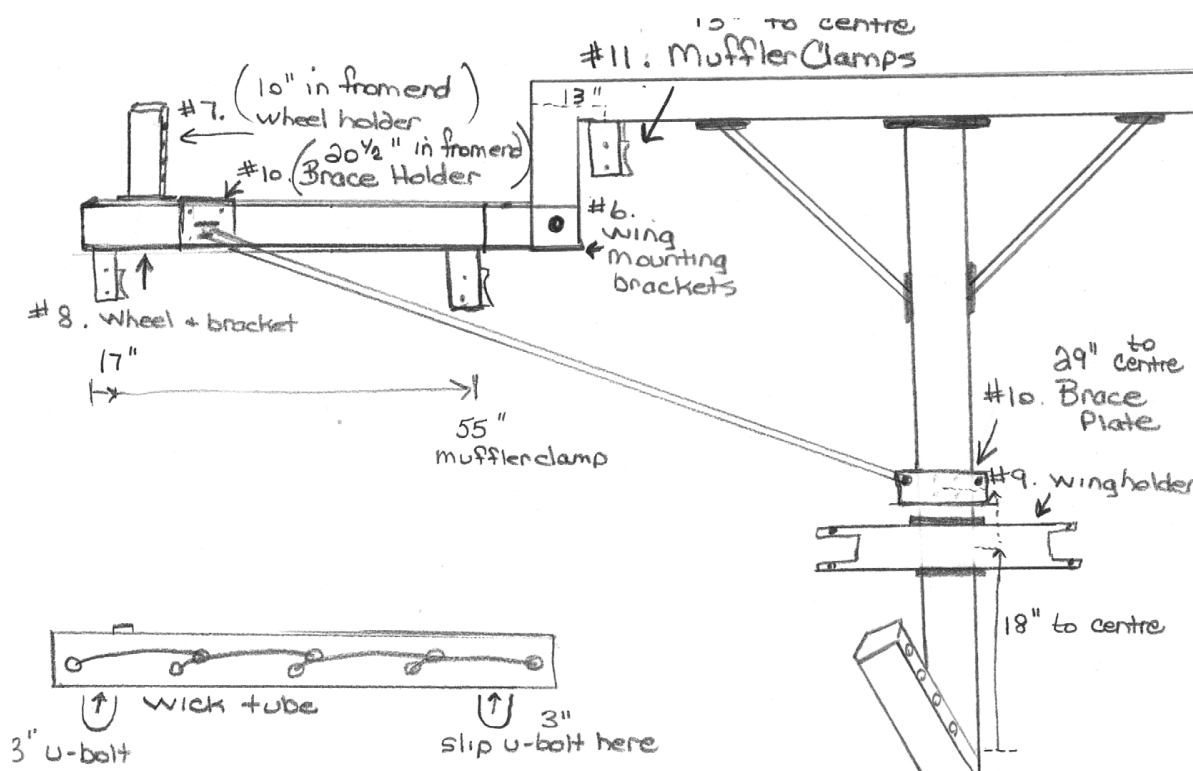

6. Add the wings using the 2 wing mounting brackets with the 4- 1/2 x 3 1/2 bolts and 1/2\" lock nuts.
7. Bolt on 2 wheel holders using u-bolts, close to the ends of the wings.
8. Slide in the wheels (that are mounted to their bracket) and secure with a pin and hair pin.
9. Put on the wing holder, placing it at the front of the main tongue using u-bolts. Place it so the wings rest into it and lock in using pins and hair pins.
10. Bolt on the brace plate behind the wing holder, and bolt on the brace holder onto the wings using u-bolts. Bolt the long braces into the brace plate with 1/2 x 2 1/2\" bolts and lock nuts and pin the other end into the brace holder with a pin and hair pin.
11. Bolt on the muffler clamps using u-bolts. Place them approx. 4\" in from the ends of the wings and from the main frame. The ones on the wings closest to the hinge must go in farther. (hold a wick tube up to it and you will know where they have to go)
12. You are now ready to bolt on the wick tubes. The fill cap goes to the top, the ropes face forward. Use the round u-bolt to mount these. They slip around the wick tube and get fastened to the muffler clamps.